

Flare T-joint assembly type 60/38-S/60

Stock codes: See table below

TECHNICAL DATA SHEET TB3401 REVISION A DATE OF ISSUE 05 Oct 2012

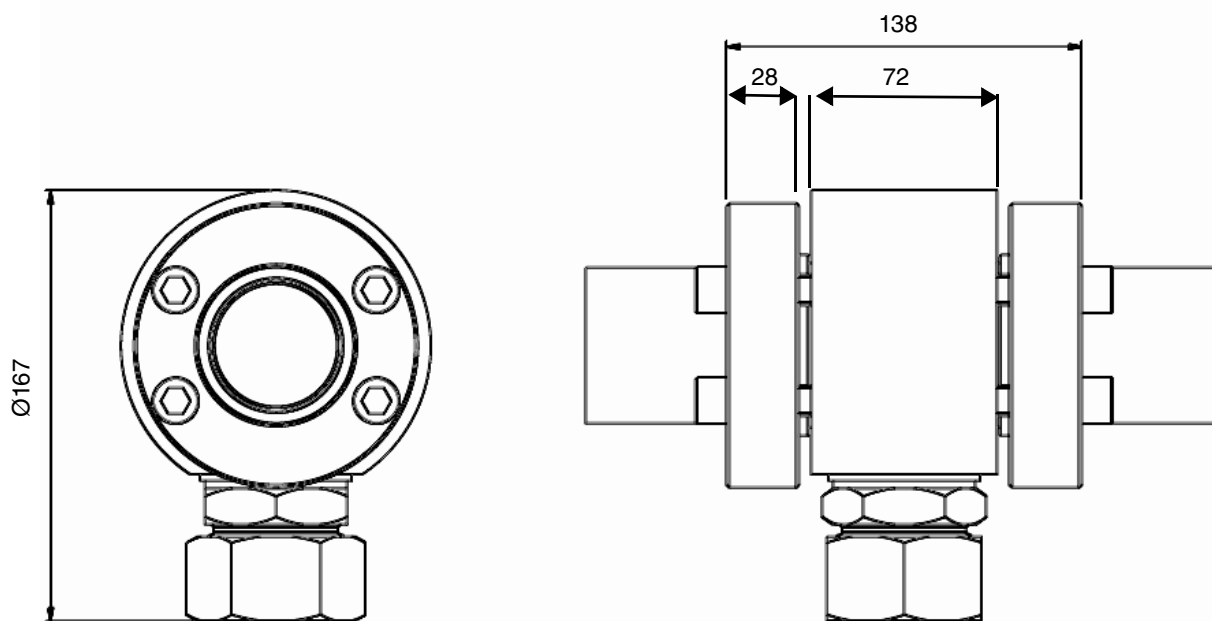

Pipe O.D. Ø60,3 x 3,91 (not included in the supply)

| Stock code | A-0003210 | B04205 |
|------------|--|--|
| Joint body | Stainless steel (EN 1.4404 / AISI 316) | Stainless steel (EN 1.4305 / AISI 303) |
| Flanges | Steel, Zn finishing | Steel, Zn finishing |
| Cones | AISI 316 | Brass |
| Usit | AISI 316 | Steel, Zn finishing |
| Bolts | Steel, Zn finishing | Steel, Zn finishing |
| Nuts | Steel, Zn finishing | Steel, Zn finishing |

| General | Max. pressure | 190 bar |
|---------|---------------|---------|
| | | |

Flare T-joint assembly type 60/38-S/60

Pipe connection structure

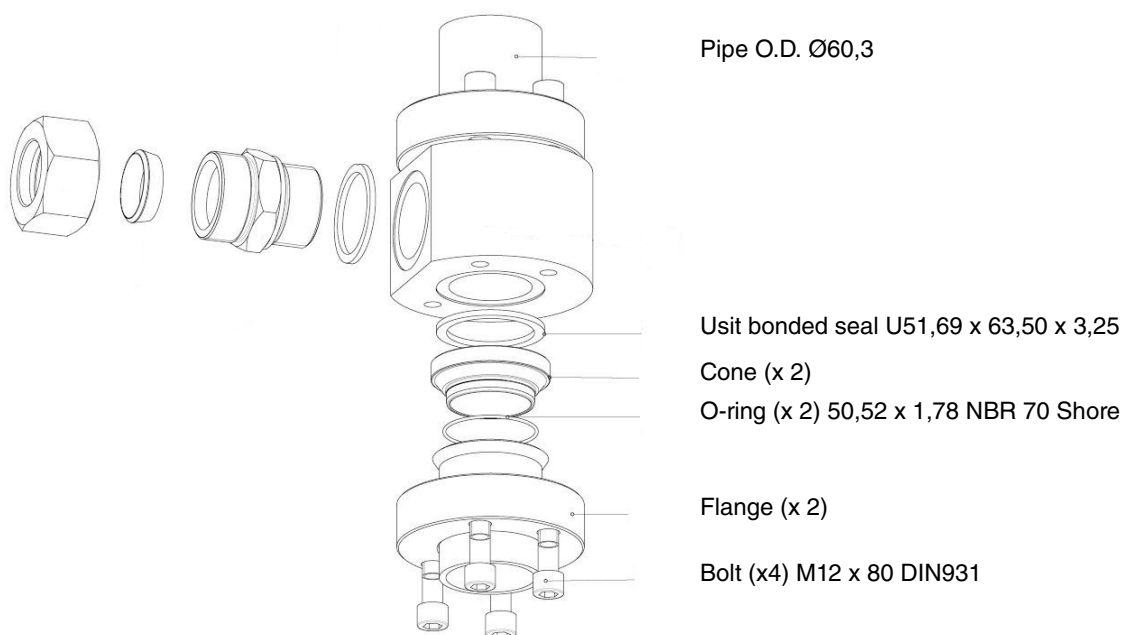

Pipe moulding instruction for flare T-joint assembly type 60/38-S/60

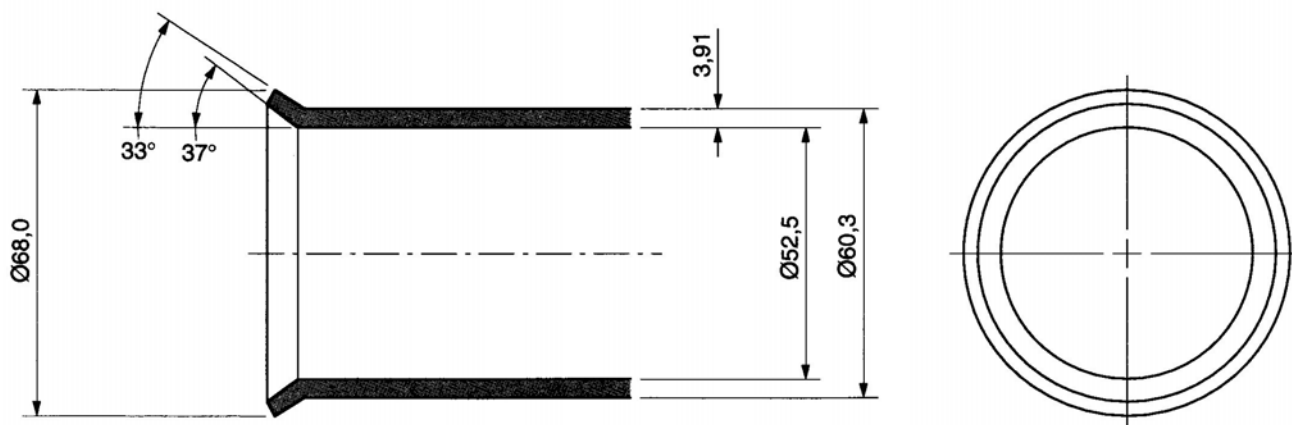

Marioff Corporation Oy • Virnatie 3, 01300 Vantaa, Finland • Tel. +358 10 6880 000 • Fax +358 10 6880 010 • www.marioff.com